



IMEL
PARK
FUN LIGHTS

We Light up your
Entertainments

INDICE

2 IMEL PARK

4 LED

13 CABOCHON E 14

17 CABOCHON E 10

18 CABOCHON DA INCASSO

*Cabochoons encastrables - Fitted cabochoon
Cabochoon zum Einlassen - Cabochoones empotrados*

24 FANALI E PROETTORI LUMINOSI

*Projecteurs, Projecteurs lumineux - Lamp, Light projectors
Schlusslichter, Lichtprojektoren - Focos, Proyectores luminosos*

26 CENTRALINE, SPINE E PRESE

*Centrales eléctricas, Fiches et prises - Control units, Plugs and sockets - Steueranlagen und elektrischen, Steckern und Steckdosen
Centralitas eléctricas, Clavijas y tomas*

27 LAMPADE

Lampe - Lamp - Lampe - Lampara

28 SCHEDE TECNICHE

*Fiches techniques Led - Led Technical Data Sheet
Technische Beschreibung Led - Fichas de datos Led*

43 APPLICAZIONI

Applications - Applications - Anwendungen - Aplicaciones



Servizio e innovazione made in Italy

Leader internazionale nella produzione e commercializzazione di luminarie e soggetti decorativi per luna park e parchi giochi.

La trentennale esperienza si fonda con l'innovazione. Imel park offre la più completa gamma di Cabochoon E10 E14 E27 da esterni e da incasso abbinata ad ogni soluzione di portalampe e lampade a led. In particolare le lampade a led RGB offrono spettacolari soluzioni multicolore con giochi di luce e attraverso l'abbinamento di centraline elettroniche le insegne luminose e gli impianti ottengono una possibilità infinita di soluzioni.

Servizi, consulenza laboratorio assemblaggio e assistenza tecnica

Imel Park è l'unico produttore di luminarie per attrazioni mobili e viaggianti ad essere dotato di un completo laboratorio interno nel quale si realizzano le personalizzazioni di giochi, giostre e attrazioni varie. Grazie all'elevata esperienza del personale e all'ampissima gamma di prodotti siamo in grado di dare un servizio di consulenza tecnica ed estetica per ogni problematica. Dalla progettazione e realizzazione di nuovi impianti, inclusi quadri e centraline di comando e controllo al rinnovamento di impianti esistenti.

Imel Park fornisce assistenza tecnica direttamente con proprio personale.



Service et Innovation made in Italy.

Leader international dans la production et la commercialisation de luminaires et d'objets de décoration pour parcs d'attractions et parcs à thèmes. L'expérience de trente ans s'unit à l'innovation. Imel park offre la gamme la plus complète de Cabochons E10, E14, E27 pour extérieur et encastrables, assortie à toutes les solutions de douilles et de lampes à diodes. Les lampes à diodes RGB offrent entre autres des solutions multicolores spectaculaires avec jeux de lumières. Grâce à la combinaison de centrales électroniques, les enseignes lumineuses et les installations ont à disposition une possibilité infinie de solutions.

Services, consultation laboratoire, assemblage et assistance technique.

Imel Park est l'unique producteur de luminaires pour attractions mobiles et roulantes à être doté d'un laboratoire interne complet dans lequel sont réalisées les personnalisations de jeux, manèges et attractions variées.

Grâce à la longue expérience du personnel et à la très large gamme de produits, nous sommes en mesure d'offrir un service de consultation technique et esthétique pour chaque problématique.

De la conception et la réalisation de nouvelles installations, y-compris tableaux et centrales de commande et de contrôle, à la rénovation d'installations déjà existantes, Imel Park fournit directement l'assistance technique par l'intermédiaire de son personnel.



Service and Innovation made in Italy.

International leader in the production and marketing of lights and decorative lighting elements for funfairs and amusement parks.

Its thirty years of experience are based on innovation. Imel park offers the most comprehensive range of E10/E14/E27 cabochons for external use and fitting, combined with every possible socket and LED lamp solution. In particular, RGB LED lamps provide spectacular multicoloured solutions with plays of light, and by combining with an electronic control unit, luminous signs and lighting systems can offer an infinite number of possibilities.

Services, consultancy, assembly workshop and technical assistance.

Imel Park is the only manufacturer of lights for mobile and travelling attractions to be equipped with a complete in-house workshop, in which customised lighting is created for rides and attractions of various kinds. Thanks to the vast experience of our staff and our extensive range of products, we are able to provide a technical and aesthetic consultancy service for any kind of problem. From the design and creation of new systems, including control units and electric panels, to the renewal of existing systems. Imel Park provides direct technical assistance with its own staff.



Service und Innovation made in Italy.

Internationaler Marktführer in Herstellung und Vertrieb von Beleuchtungen und Dekorationsgegenständen für Vergnügungs- und Spielparks. Die dreißigjährige Erfahrung verschmilzt mit Innovation. Imel Park bietet die vollständigste Linie von Cabochons E10, E14 und E27 für Außenbeleuchtung und zum Einlassen, in Kombination mit jeder Art von Lampenfassungen und Led-Lampen. Die RGB-Led-Lampen insbesondere bieten spektakuläre, vielfarbige Lösungen mit Lichtspielen, und in Kombination mit elektronischen Steuerzentralen kann für Leuchtschriften und Anlagen eine unendliche Zahl von Lösungen erzielt werden.

Service, beratung, montagewerkstatt und technische unterstützung.

Imel Park ist der einzige Hersteller von Beleuchtungen für mobile und fahrende Attraktionen, der mit einer kompletten Werkstatt für die Realisierung und Personalisierung von Spielen, Karussellen und sonstigen Attraktionen ausgestattet ist.

Dank der großen Erfahrung unseres Personals und dem riesigen Produktangebot sind wir in der Lage, für jede Problematik technische und ästhetische Unterstützung zu liefern. Von der Planung und Verwirklichung neuer Anlagen, einschließlich der Steuer- und Kontrollzentralen, bis zur Erneuerung bereits bestehender Anlagen. Die technische Unterstützung liefert Imel Park durch ihr eigenes Personal.



Servicio e Innovación made in Italy.

Líder internacional en la producción y comercialización de sistemas de iluminación y sujetos decorativos para parques de atracciones y parques de juegos. Los treinta años de experiencia, se funden con la innovación. Imel park ofrece la más completa gama de cabochon e10 e14 e27 para exteriores y empotrados, combinada a cualquier solución de portalámparas y lámparas led. En particular, las lámparas led rgb, ofrecen soluciones multicolores extraordinarias, con juegos de luz, y, a través de la combinación de centralitas electrónicas, los rótulos luminosos y las instalaciones obtienen una posibilidad infinita de soluciones.

Servicios, asesoría laboratorio ensamblado y asistencia técnica.

Imel Park, es el único productor de sistemas de iluminación para atracciones móviles que puede contar con un completo laboratorio interior en el que se realizan las personalizaciones de juegos, tióvivos y atracciones. Gracias a la elevada experiencia del personal y a una muy amplia gama de productos, podemos ofrecer un servicio de asesoramiento técnico y estético para cualquier problemática. Desde el diseño y la realización de nuevas instalaciones, incluidos los cuadros y las centralitas de mando y control, hasta la renovación de instalaciones existentes. Imel Park, ofrece asistencia técnica directamente, a través de personal propio.

FARETTO "RAINBOW"

OSRAM LED

12 LED
24V DC
3W - Ø 70 mm x h 20 mm



art. 265

Collegamento a serrafilo. Multicolor RGB.
Alta luminosità. LEDs pilotati anche con segnale DMX 512.
Angolo luminosità 120°



Connexion à serrefil. Multicolore RGB.
Haute luminosité. LEDs contrôlés aussi par DMX 512. Angle
de luminosité 120°



Connection clamp wires. Multicolor RGB.
High brightness. LEDs piloted even by DMX 512. Angle of
brightness 120°



Anschluss Klemme. Multicolor RGB.
Hohe Helligkeit. LEDs über auch DMX 512 angesteuert.
Winkel Helligkeit 120°



Conexión con la abrazadera. Multicolor RGB.
Alto brillo. LEDs conducidos también por DMX 512. Ángulo
de brillo 120°



Ø 70 mm



Art. 265

STAGGE

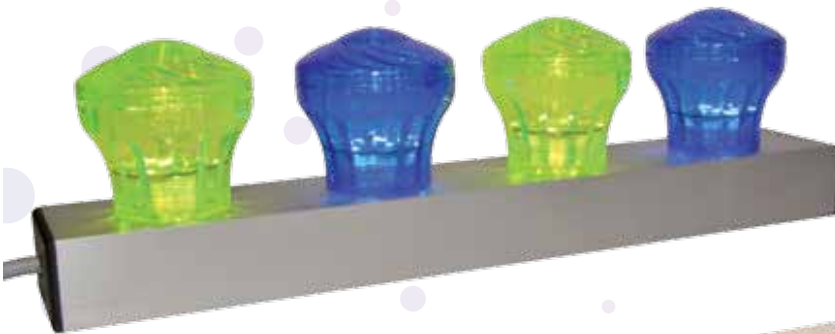

27 mm

41 mm

art. 313

17 mm

31 mm

art. 312

art. 399

51 mm

31 mm

art. 317

art. 319

art. 319

art. 400

Art. 312 - 313 Barra in plastica per impianti con cabochon.

Art. 399 Barra in alluminio per impianti con cabochon.
Possono essere tagliate della lunghezza desiderata.



Art. 312 - 313 Barre en plastique blanche pour installations avec
cabochon.

Art. 399 Barre en aluminium pour installations avec cabochon.
Elle peut être coupée à la longueur désirée.



Art. 312 - 313 White plastic bar for installations with cabochon.

Art. 399 Aluminum bar for installations with cabochon.
It can be cut to the desired length.



Art. 312 - 313 Weiße Kunststoffleiste für Systeme mit Cabochon.

Art. 399 Aluminium Leiste für Systeme mit Cabochon.
Es kann auf die gewünschte Länge geschnitten werden.



Art. 312 - 313 Blanca barra de plástico para sistemas con cabujón.

Art. 399 Barra de aluminio para sistemas con cabujón.
Se puede cortar a la longitud deseada.





waterproof

OSRAM LED

E14 - E27
24V AC/DC
1W

VINTAGE GLOBE

 LED ad alta efficacia non distinguibile grazie ad uno speciale materiale plastico. Effetto Vintage.
Disponibile in tutti i colori anche RGB su richiesta.

 Led très efficaces que ne se distingue pas grâce à une matière plastique spécial. Effet vintage.
Disponibile en tous les couleurs aussi en RGB sur demande.

 Led high efficiency not distinguishable thanks to a special plastic material. Vintage effect.
Available in all the colours also in RGB on demand.

 Led sehr effektiv nicht zu unterscheiden dank eines speziellen Materials plastik. Vintage-Effekt.
Verfügbar in allen Farben auf abfrage auch in RGB.

 Led altamente eficaces no distinguibles gracias a un material especial plastico. Efecto Vintage.
Disponibile en todos los colores, también RGB a petición.



art. 266



art. 266

COLORI DISPONIBILI:



waterproof

FARETTO FLAT

OSRAM LED

12 LED AC/DC
24V
1W

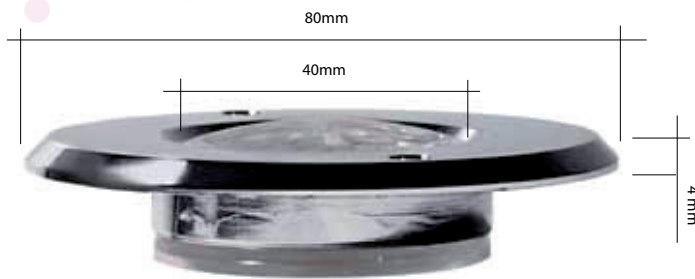

art. 194



Bianco
Blanc
White
Weiß
Blanco

Nero
Noir
Black
Schwarz
Negro

Cromato
Chrome
Chrome
Chrom
Cromo

Satinato
Satin
Satin
Satin
Satinado

COLORI DISPONIBILI:



Ultrapiatto, alta luminosità, tenuta stagna IP65, fissaggio con 2 viti.
Disponibile in tutti i colori anche RGB su richiesta.



Extraplat, haute luminosité étanchéité IP65, fixation avec 2 vis.
Disponibile en tous les couleurs aussi en RGB sur demande.



Extra plat, high brightness, watertight IP65, fitting with 2 screws.
Available in all the colours also in RGB on demand.



Ultraflach, mit hoher Helligkeit, wasserdicht IP65, Befestigung mit 2 Schrauben.
Verfügbar in allen Farben auf abfrage auch in RGB.



Extraplat, de alta luminosidad, hermeticidad IP65, fijación con 2 tornillos.
Disponibile en todos los colores, también RGB a petición.



PIXEL

OSRAM LED

6 LED AC/DC
24V
1W



art. 264

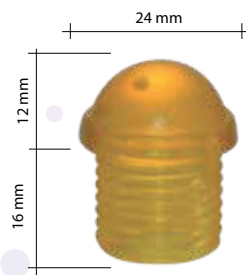

COLORI DISPONIBILI:



Punto luce singolo alta luminosità massima protezione all'umidità versatilità in tutte le applicazioni.
Disponibile in tutti i colori anche RGB su richiesta.



Un seul point de lumière à haute luminosité maximum de polyvalence protection contre l'humidité dans toutes les applications.
Disponibile en tous les couleurs aussi en RGB sur demande.



Single point of light high brightness, maximum moisture protection, versatility in all applications.
Available in all the colours also in RGB on demand.



Einzelne Leuchte, maximal Feuchtigkeitsgeschützt, sehr vielseitig in alle Anwendungen.
Verfügbar in allen Farben auf abfrage auch in RGB.





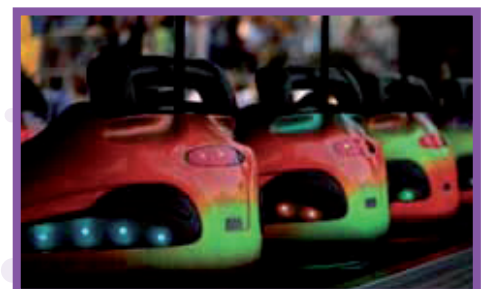

Un único punto de luz alta versalidad, alta luminosidad, protección contra la humedad en todas las aplicaciones.
Disponibile en todos los colores, también RGB a petición.



waterproof



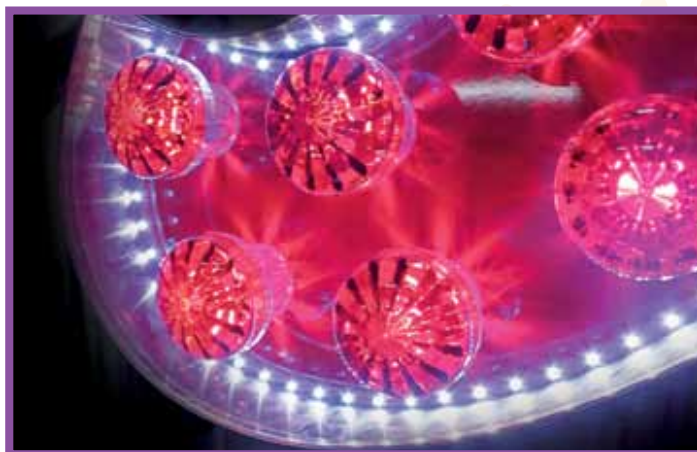

LED LUX VERTICALE
VERTICAL

60 LED
12V AC/DC
15W

-  12V 15W 60 Led al mt. isolata per esterni, **disponibile solo bianca**. In bobine da 3mt.
-  12V 15W 60 Led par mt. étanche, **disponible seulement blanche**. En bobines de 3mt.
-  12V 15W 60 Led for mt. waterproof, **available only in white**. Reels of 3mt.
-  12V 15W 60 Led pro meter, isoliert zum Aussengebrauch, **nur in weiß erhältlich**. In rollen 3mt.
-  12V 15W 60 Led por metro, aislada para externos, **sólo está disponible en color blanco**. En bobinas 3mt.



60 LED
12V/24V AC/DC
4W
PIATTA

-  12V/24V 4W 60 Led al mt. isolata per esterni, **disponibile in tutti i colori**. In bobine da 5mt.
-  12V/24V 4W 60 Led par mt. étanche, **disponible dans tous les couleurs**. En bobines de 5mt.
-  12V/24V 4W 60 Led for mt. waterproof, **available in all the colours**. Reels of 5mt.
-  12V/24V 4W 60 Led pro meter, isoliert zum Aussengebrauch, **in alle Farben**. In rollen 5mt.
-  12V/24V 4W 60 Led por metro, aislada para externos, **disponible en todos los colores**. En bobinas 5mt.



RGB





White

Blue

Green

LED LUX ORIZZONTALE
HORIZONTAL

TUBO LED
24V AC/DC

-  Protetto da tubo in PMMA trasparente tenuta stagna.
-  Protégé par un tube en PMMA transparent.
-  Protected by a PMMA transparent tube.
-  Von durchsichtigem PMMA-Rohr geschützt, wasserdicht.
-  Protegido por el tubo de PMMA transparente, hermético.

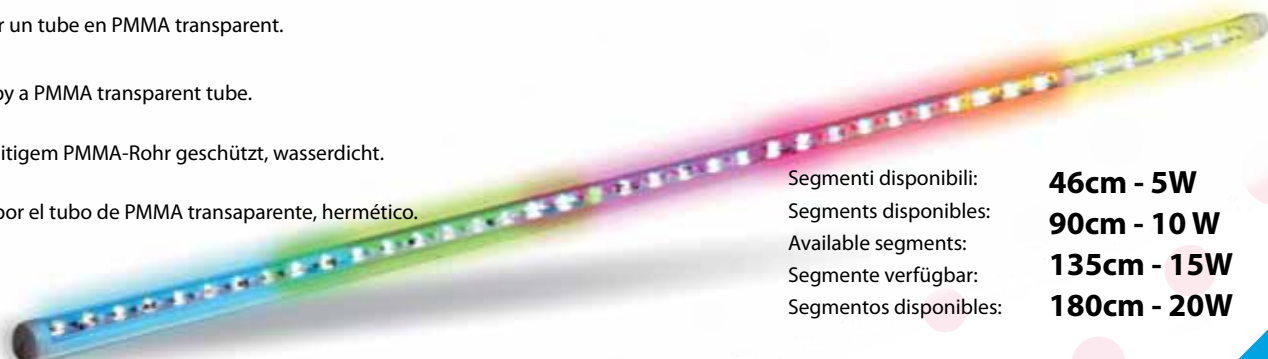

Segmenti disponibili: **46cm - 5W**
 Segments disponibles: **90cm - 10 W**
 Available segments: **135cm - 15W**
 Segmente verfügbar: **180cm - 20W**
 Segmentos disponibles: **180cm - 20W**

Possibilità di personalizzare i colori, anche RGB - Possibility of personalizing the colors, even RGB - Possibilité de personnaliser les couleurs, même RGB - Möglichkeit der Personalisierung der Farben, auch RGB - Posibilidad de personalizar los colores, incluso RGB

waterproof

LED

DICRO LED DM 35 AC/DC

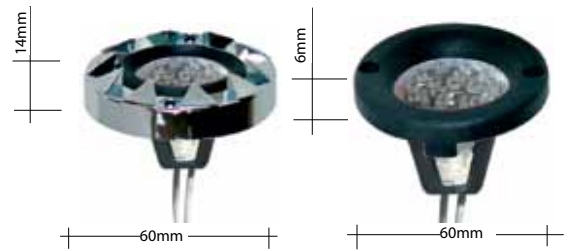

COLORI DISPONIBILI:



Lampade Disponibili - Ampoules Disponibles - Available Lamps
Verfügbar Lampen - Lámparas Disponibles:



●●●●●●●●	●●●●●●●●
art. 186:	art. 281:
ALOGENA	LED
Ø 35mm	Ø 35mm
12v/24v - 20w	12v/24v - 1,5w

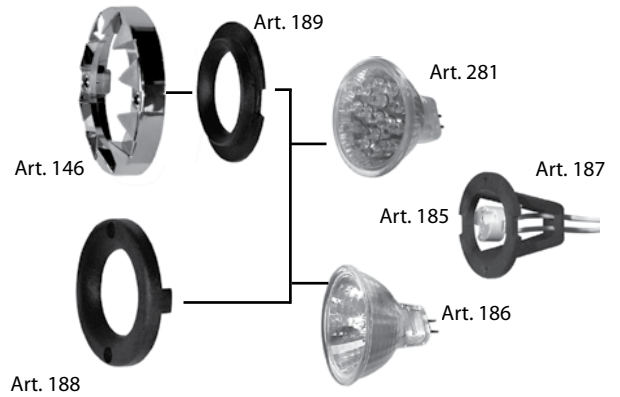

DICRO LED DM 51 AC/DC



COLORI DISPONIBILI:



Lampade Disponibili - Ampoules Disponibles - Available Lamps
Verfügbar Lampen - Lámparas Disponibles:





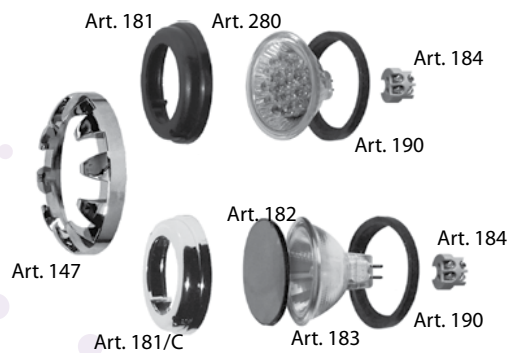

●	●●●●●●●●
art. 183	art. 280
ALOGENA	LED
Ø 51mm	Ø 51mm
12v/24v - 20w	12v/24v - 1,5w



Waterproof

OSRAM LED

12 LEDS
24V AC/DC
1,5W

-  Tenuta stagna, senza portalamпада salvaspazio alta luminosità.
-  Étanche, sans douille, haute luminosité, extra plat.
-  Watertight, without lamp, holder, high brightness, extraplat.
-  Ohne Fassung, Raumersparend, mit hoher Helligkeit.
-  Hermético, sin portalamπά, ahorro de espacio, alta luminosidad.



COLORI DISPONIBILI:



Clear Red Yellow Orange Green Blue

SPRINGLED



art. 147



art. 282





Ø 64 mm

Con o senza ghiera cromata (art.147)
Avec ou sans embout chromé (art.147)
With or without chrome ring (art.147)
Mit oder ohne verchromter Anschlussring (art.147)
Con o sin anillo cromado (art.147)

OSRAM LED

12 LEDS
24V AC/DC

PMMA trasparente con lampada colorata
Transparent PMMA with colored lamp
PMMA transparent avec ampoule colorée
Transparente PMMA mit farbigen birne
PMMA transparente con bombilla de color

-  Fissaggio solo con ghiera cromata o colorata.
-  Fixation seulement avec embout chromé ou coloré.
-  Fixing only with chromed or colored ring.
-  Befestigung nur mit verchromtem oder farbigem Ring.
-  Fijación sólo con anillo cromado o colorado.



COLORI DISPONIBILI:



Clear Phosph. Yellow Orange Red Blue Green

DAISY LED



art. 146L

Ø 41 mm

Ø 60 mm



art. 146

Ø 60 mm



art. 180

waterproof

HALOSPOT LED PAR36

24V AC
5W



Art. 501 Ø 136mm
Cerchio cromato
Cercle chromè
Chrome Felge
Chromed ring
Aro cromado

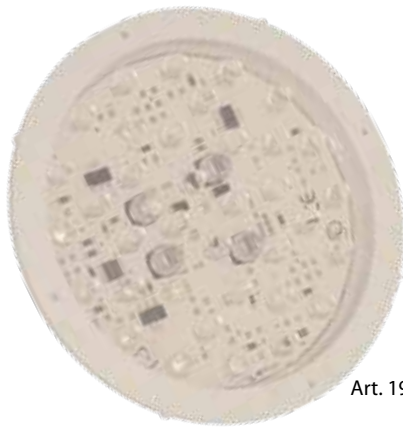

Art. 196 Ø 90mm

- Tecnologia Led ULTRA WHITE 
- Technologie led POWERWHITE 
- POWERWHITE led Technology 
- POWERWHITE Technologie 
- Tecnologia POWERWHITE 

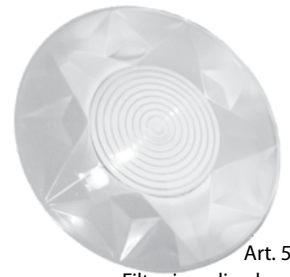

Art. 510
Filtro in policarbonato
Filtre en polycarbonate
Polycarbonate filter
Polykarbonatfilter
Filtro de policarbonato

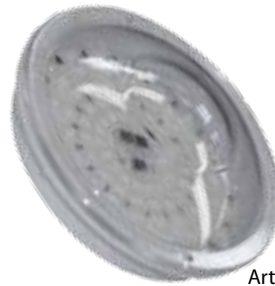

Art. 510/L

Con filtri colorati - Avec filtres colorés - With coloured filter - Mit farbigen filtern - Con filtros de colores



Clear



Phosph. Yellow



Orange



Red



Blue





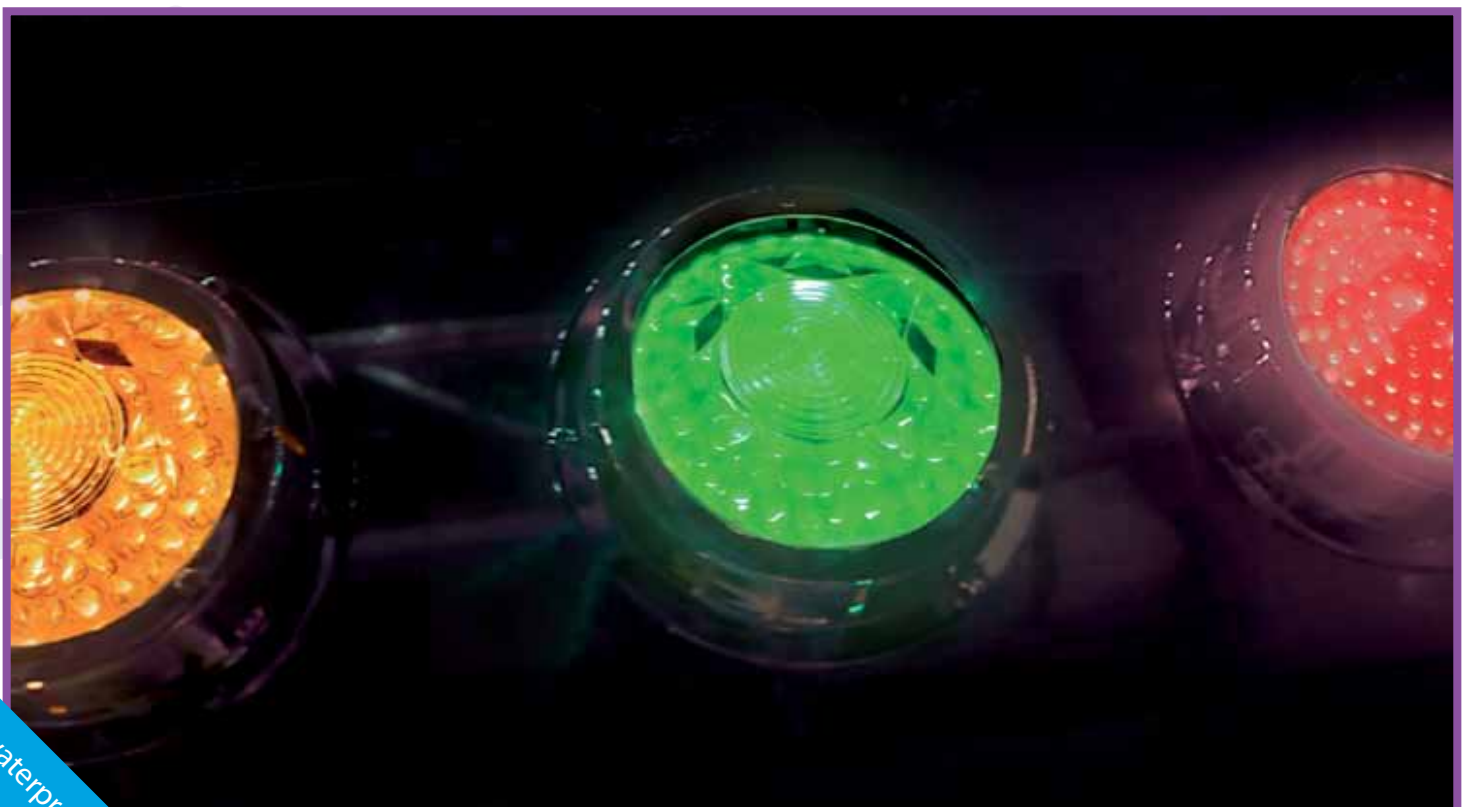

Green



waterproof

OSRAM LED

24V AC/DC
1W

-  Tecnologia LED Tricolor. Luci rotanti con centralina 3 canali. Resistente agli urti.
-  Technologie led tricolor. Gyrophares avec appareil électrique, 3 canaux. Résistant aux chocs.
-  Led Tricolor Technology. Rotating lights with control unit, 3 channels. Impact-resistant.
-  Tricolor led Technologie. Drehende Leuchten, mit Schaltpult, 3 Kanäle. Stoßbeständig.
-  Tecnologia led Tricolor. Luz giratoria, con unidad de control, 3 canales. Resistente a golpes.

ROTORLED

Art. 197/S \varnothing 65mm

Art. 147



Art.134/L



Art. 147







Art.134/D



Art. 197/S

OSRAM LED

24V AC/DC
5W

-  Tecnologia LED Multicolor. Luci rotanti con centralina 3 canali. Resistente agli urti.
-  Technologie led Multicolor. Gyrophares avec appareil électrique, 3 canaux.. Résistant aux chocs.
-  Led Multicolor Technology. Rotating lights with control unit, 3 channels. Impact-resistant.
-  Multicolor led Technologie. Drehende Leuchten, mit Schaltpult, 3 Kanäle. Stoßbeständig.
-  Tecnologia led Multicolor. Luz giratoria, con unidad de control, 3 canales. Resistente a golpes.

ROTORLED PAR36

Art. 197 \varnothing 90mm

Art. 501



Art. 501



Art. 510



Art. 197



Art.510/L







waterproof

MULTICOLOR RGB

OSRAM LED

E14
24V AC/DC
1,5W - Ø 38mm

Art. 267

- 6 Led RGB 10 canali, lampada compatibile in tutti i tipi di applicazioni, colori brillanti. 
- 6 led RGB, 10 canaux, lampe compatible pour tous les types d'application, couleurs brillantes. 
- 6 led RGB, 10 channels, compatible lamp in alla types of application, brilliant color. 
- 6 led RGB, 10 kanäle Lampe kompatibel in allen Arten von Anwendungen, brillante Farben. 
- 6 led RGB, 10 canales, lámpara compatible en todo tipo de aplicaciones, colores brillantes. 

Può essere utilizzato all'interno di - Peut être utilisé à l'intérieur - Can be used inside of - Kann eingesetzt werden im - Meglio se puede emlevar al interior de:



TURBO S



ASTRO



ATLAS



TURBO S AD INCASSO



ASTRO AD INCASSO



DIAMANTE



DAISY LED



SPRINGLED



SPOT E 14



waterproof



COLORI DISPONIBILI:

- T1 Red
- T2 Yellow
- T3 Green
- T4 Orange
- T5 Fuchsia
- T6 White
- T7 Clear
- T8 Blue
- T9 Phosph.P
- T10 Phosph.Y
- T11 Phosph.O
- T12 Purple

Lampade Disponibili - Ampoules Disponibles - Available Lamps - Verfügbar Lampen - Lámparas Disponibles:



art. 267 = E14
24v - 1,5w
6 LED RGB
Multicolor



11 LED
art. 258 = E14
24v - 1w
art. 259 = E14
60v - 1w



11 LED
art. 260 = E14
24v - 1w
art. 261 = E14
60v - 1w



Strobe Led
art. 283
24V



Strobe
art. 872 60V
A art. 873 110V
art. 874 220V Pilot
B art. 875 220V



E14
art. 203 60V - 8w
art. 205 60V - 10w
art. 208 24V - 5w
art. 209 14V - 5w L.
art. 211 230V - 7w

Portampada Disponibili - Douilles Disponibles
Available Sockets - Verfügbar Fassungen
Portalámparas Disponibles:



art. 140



art. 122



art. 104

Autoestinguenti
Fireproof

Accessori - Accessoires - Accessories Zubehör - Accesorios:

Ghiera - Ring - Anneau - Ring - Anillo:



art. 129



art. 142



art. 108

Portampada - Douilles - Sockets
Fassungen - Portalámparas:



art. 120



art. 123



art. 125



art. 121

Adattatore E27 - Adapter E27
- Adapter E27 - Adapteur E27 -
Adaptator E27:



art. 128

art. 127
E27 - E14



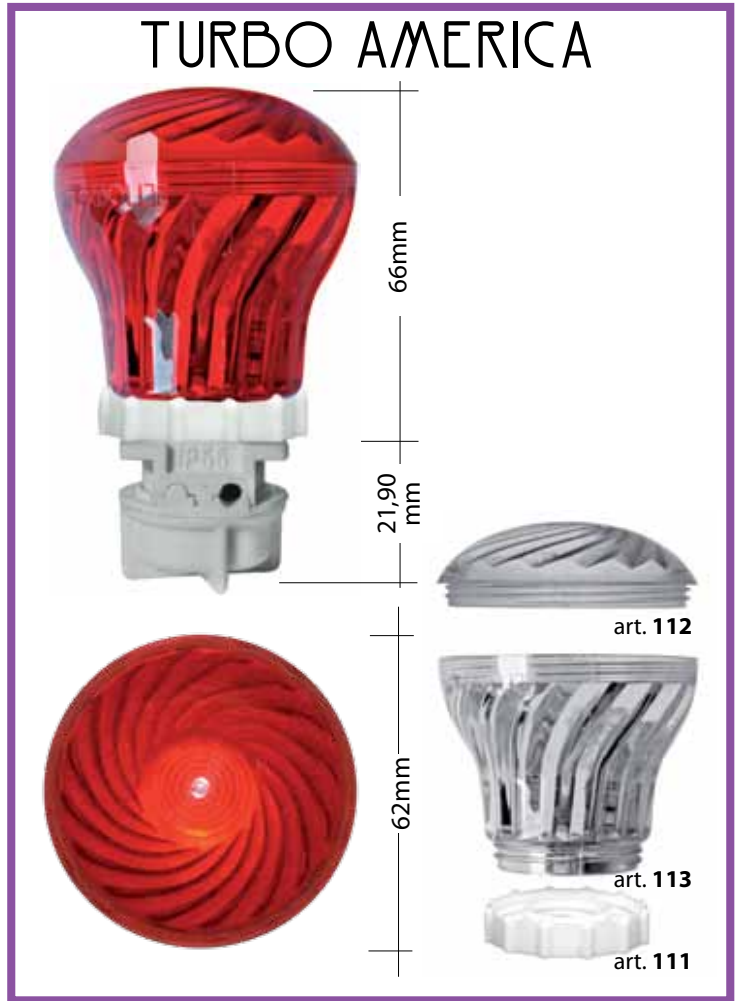

COLORI DISPONIBILI:

- T1 Red
- T2 Yellow
- T3 Green
- T4 Orange
- T5 Fuchsia
- T6 White
- T7 Clear
- T8 Blue
- T9 Phosph.P
- T10 Phosph.Y
- T11 Phosph.O
- T12 Purple

Lampade Disponibili - Ampoules Disponibles - Available Lamps - Verfügbar Lampen - Lámparas Disponibles:



art. 267 = E14
24v - 1,5w
6 LED RGB
Multicolor



T1 LED
art. 258 = E14
24v - 1w
art. 259 = E14
60v - 1w



T1 LED
art. 260 = E14
24v - 1w
art. 261 = E14
60v - 1w



Strobo Led
art. 283
24V



Strobo
art. 872 60V
A art. 873 110V
art. 874 220V Pilot
B art. 875 220V



E14
art. 203 60V - 8w
art. 205 60V - 10w
art. 208 24V - 5w
art. 209 14V - 5w L.
art. 211 230V - 7w

**Portampada Disponibili - Douilles Disponibles
Available Sockets - Verfügbar Fassungen
Portalámparas Disponibles:**



art. 140



art. 122



art. 104

Autoestinguenti
Fireproof

Accessori - Accessoires - Accessories Zubehör - Accesorios:

Ghiera - Ring - Anneau - Ring - Anillo:



art. 129



art. 142



art. 108

**Portampada - Douilles - Sockets
Fassungen - Portalámparas:**



art. 120



art. 123



art. 125



art. 121

**Adattatore E27- Adapter E27
- Adapter E27 - Adapteur E27 -
Adaptator E27:**



art. 128

art. 127
E27 - E14

waterproof

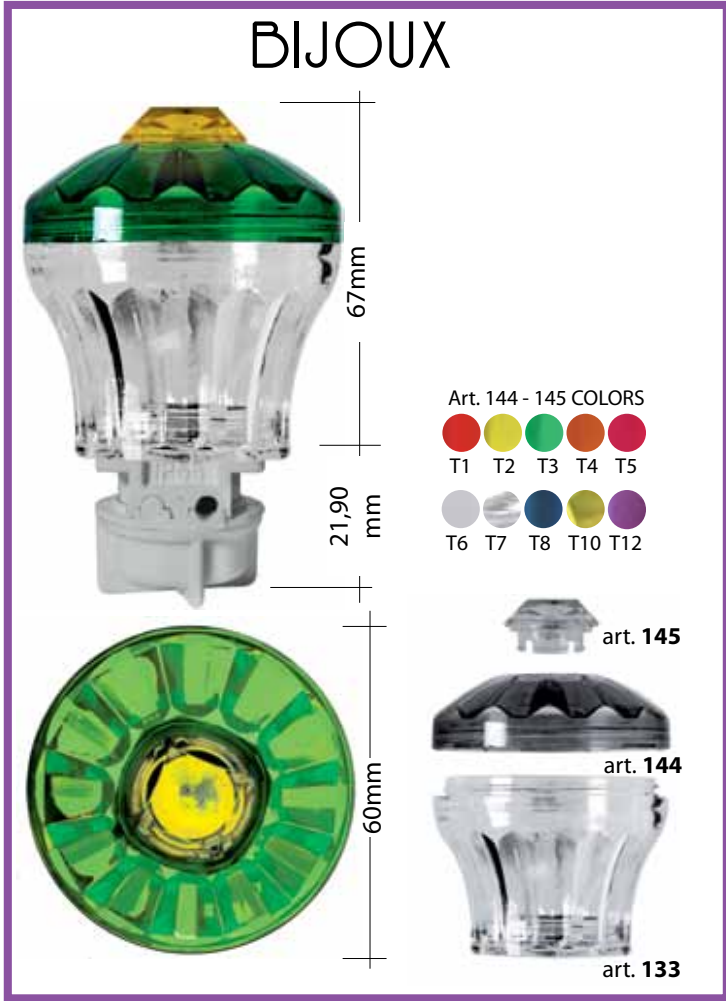

COLORI DISPONIBILI:

- T1 Red
- T2 Yellow
- T3 Green
- T4 Orange
- T5 Fuchsia
- T6 White
- T7 Clear
- T8 Blue
- T9 Phosph.P
- T10 Phosph.Y
- T11 Phosph.O
- T12 Purple

Lampade Disponibili - Ampoules Disponibles - Available Lamps - Verfügbar Lampen - Lámparas Disponibles:

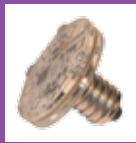

art. 267 = E14
24v - 1,5w
6 LED RGB
Multicolor



T11 LED
art. 258 = E14
24v - 1w
art. 259 = E14
60v - 1w



T11 LED
art. 260 = E14
24v - 1w
art. 261 = E14
60v - 1w



Strobo Led
art. 283
24V



Strobo
art. 872 60V
A art. 873 110V
art. 874 220V Pilot
B art. 875 220V



E14
art. 203 60V - 8w
art. 205 60V - 10w
art. 208 24V - 5w
art. 209 14V - 5w L.
art. 211 230V - 7w

Portampada Disponibili - Douilles Disponibles
Available Sockets - Verfügbar Fassungen
Portalámparas Disponibles:



art. 140



art. 104



art. 122

Autoestinguenti
Fireproof

Accessori - Accessoires - Accessories Zubehör - Accesorios:

Ghiera - Ring - Anneau - Ring -
Anillo:



art. 129



art. 142



art. 108

Portampada - Douilles - Sockets
Fassungen - Portalámparas:



art. 120



art. 123



art. 125



art. 121

Adattatore E27 - Adapter E27
- Adapter E27 - Adapteur E27 -
Adaptator E27:



art. 128

art. 127
E27 - E14

waterproof

MODULO BIG

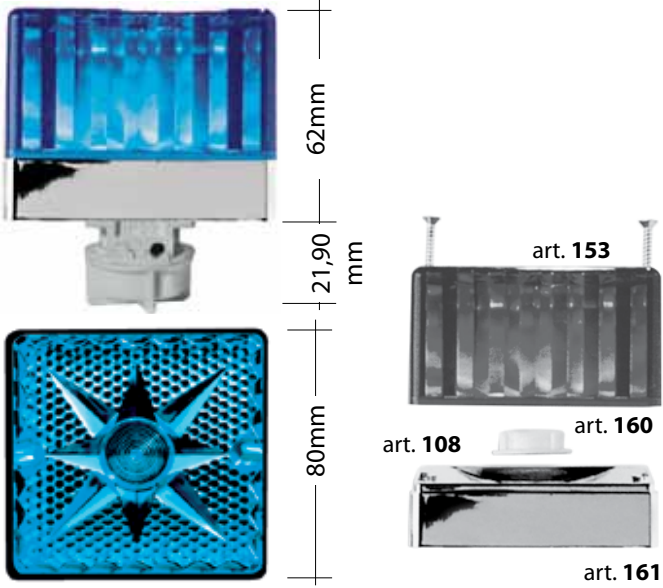

SIRIO

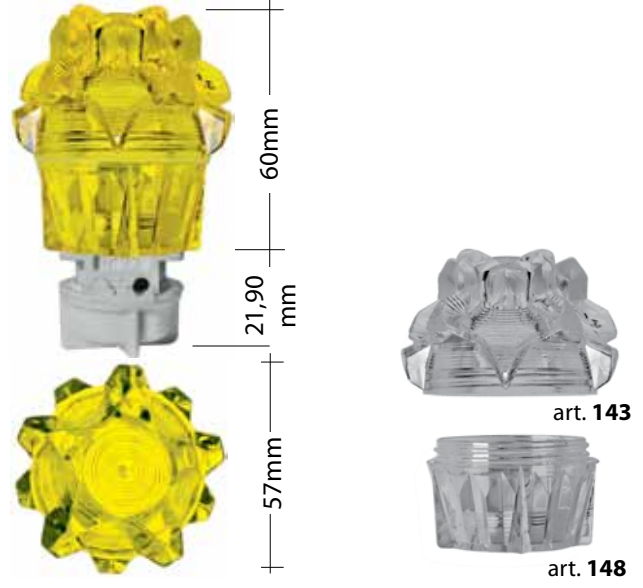

NEONLUX

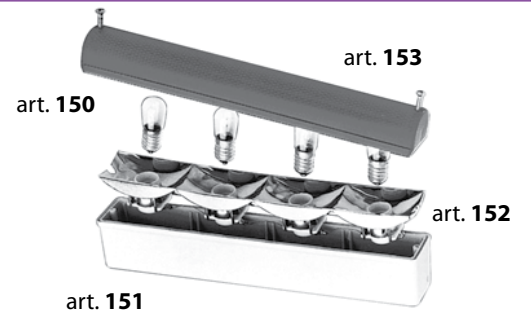
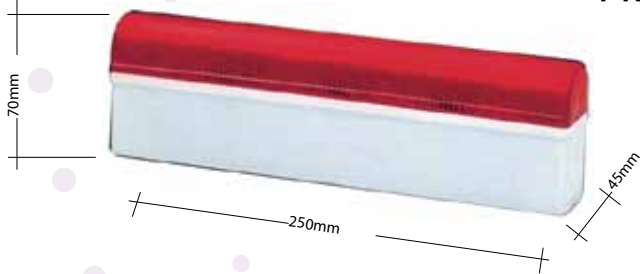

COLORI DISPONIBILI:



Lampade Disponibili - Ampoules Disponibles - Available Lamps - Verfügbar Lampen - Lámparas Disponibles:



art. 267 = E14
24v - 1,5w
6 LED RGB
Multicolor



T1 LED
art. 258 = E14
24v - 1w
art. 259 = E14
60v - 1w



T1 LED
art. 260 = E14
24v - 1w
art. 261 = E14
60v - 1w



Strobo Led
art. 283
24V



Strobo
art. 872 60V
A art. 873 110V
art. 874 220V Pilot
B art. 875 220V



E14
art. 203 60V - 8w
art. 205 60V - 10w
art. 208 24V - 5w
art. 209 14V - 5w L.
art. 211 230V - 7w

Portampada Disponibili - Douilles Disponibles
Available Sockets - Verfügbar Fassungen
Portalámparas Disponibles:



art. 140



art. 104



art. 122

Autoestinguenti
Fireproof

Accessori - Accessoires - Accessories Zubehör - Accesorios:

Ghiera - Ring - Anneau - Ring - Anillo:



art. 129



art. 142



art. 108

Portampada - Douilles - Sockets
Fassungen - Portalámparas:



art. 120



art. 123



art. 125



art. 121

Adattatore E27 - Adapter E27
- Adapter E27 - Adapteur E27 -
Adaptator E27:



art. 128

art. 127
E27 - E14

waterproof



COLORI DISPONIBILI:

- T1 Red
- T2 Yellow
- T3 Green
- T4 Orange
- T5 Fuchsia
- T6 White
- T7 Clear
- T8 Blue
- T9 Phosph.P
- T10 Phosph.Y
- T11 Phosph.O
- T12 Purple

Lampade Disponibili - Ampoules Disponibles - Available Lamps - Verfügbar Lampen - Lámparas Disponibles:



T1 LED

only ATLAS
 art. 258/E10 = E10
 24v - 1w
 art. 259/E10 = E10
 60v - 1w



8 LED

art. 268 = E10
 24v - 0,6w



8 LED

art. 269 = E10
 60v - 0,6w



8 LED

art. 271 = E10
 24v - 0,6w
 art. 272 = E10
 60v - 0,6w



E10

art. 212 60V - 4w TW/LP
 art. 213 60V - 3w
 art. 207 24V - 3w LP
 art. 202 12V - 3w

Portampada Disponibili - Douilles Disponibles
 Available Sockets - Verfügbar Fassungen
 Portalámparas Disponibles:



art. 132



art. 101



art. 122

Autoestinguenti
 Fireproof

Accessori - Accessoires - Accessories Zubehör - Accesorios:

Ghiera - Ring - Anneau - Ring - Anillo:



art. 135



art. 102



TURBO S

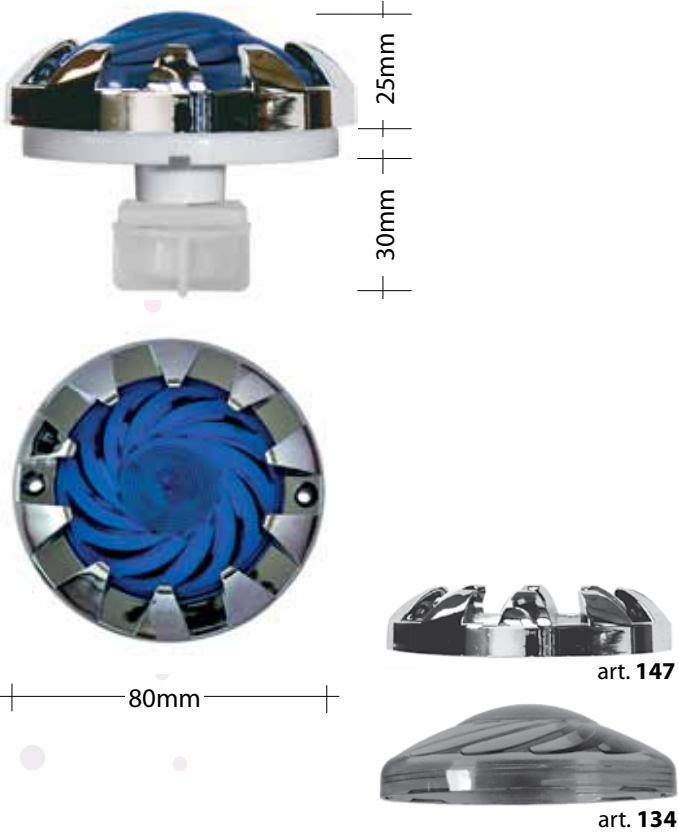

DIAMANTE

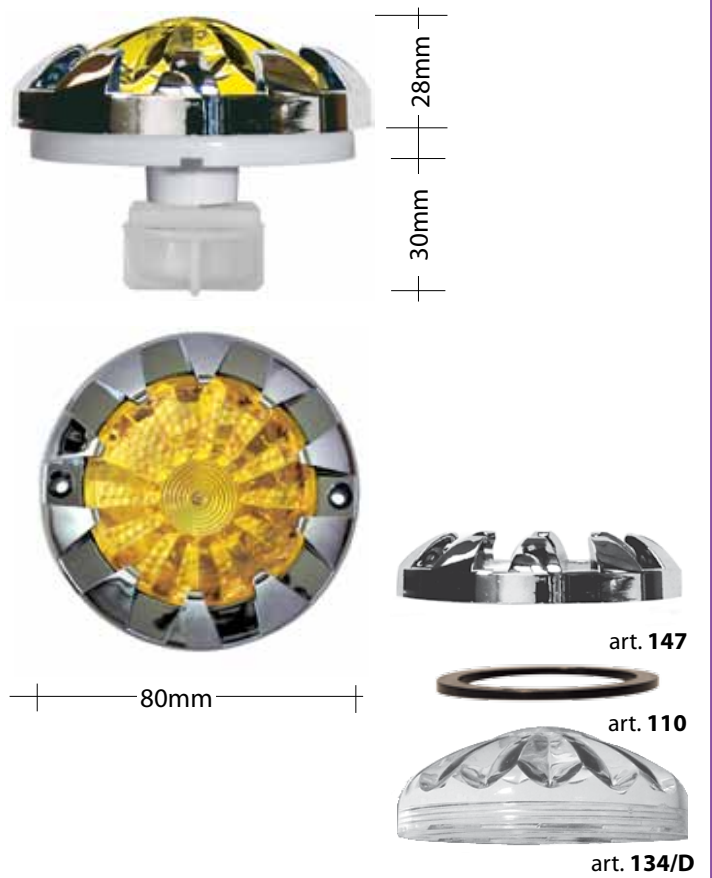

COLORI DISPONIBILI:



Lampade Disponibili - Ampoules Disponibles - Available Lamps - Verfügbar Lampen - Lámparas Disponibles:

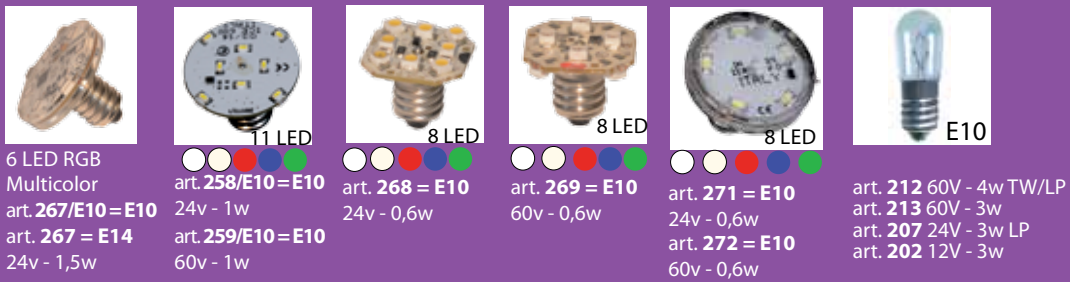

Portampada Disponibili - Douilles Disponibles - Available Sockets - Verfügbar Fassungen - Portalámparas Disponibles:

Autoestinguenti
Fireproof





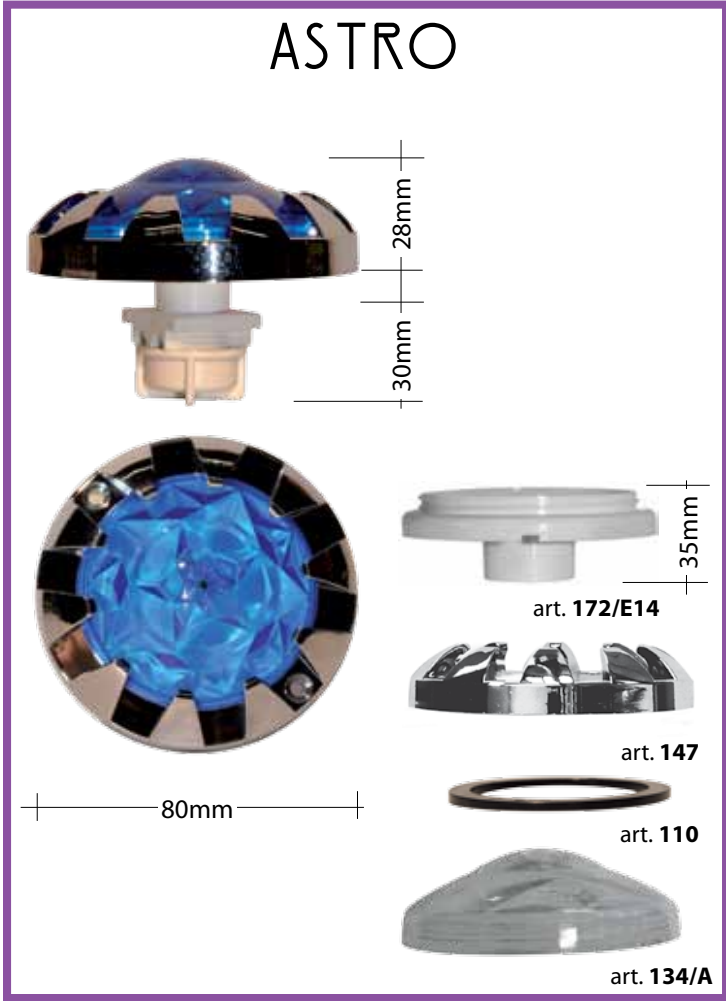



Waterproof



COLORI DISPONIBILI:

- T1 Red
- T2 Yellow
- T3 Green
- T4 Orange
- T5 Fuchsia
- T6 White
- T7 Clear
- T8 Blue
- T9 Phosph. P
Not for Bijoux
- T10 Phosph. Y
- T11 Phosph. O
Not for Bijoux
- T12 Purple

Lampade Disponibili - Ampoules Disponibles - Available Lamps - Verfügbar Lampen - Lámparas Disponibles:

					
6 LED RGB Multicolor art. 267/E10 = E10 art. 267 = E14 24v - 1,5w	11 LED art. 258/E10 = E10 24v - 1w art. 259/E10 = E10 60v - 1w	8 LED art. 268 = E10 24v - 0,6w	8 LED art. 269 = E10 60v - 0,6w	8 LED art. 271 = E10 24v - 0,6w art. 272 = E10 60v - 0,6w	E10 art. 212 60V - 4w TW/LP art. 213 60V - 3w art. 207 24V - 3w LP art. 202 12V - 3w

Portampada Disponibili - Douilles Disponibles - Available Sockets - Verfügbar Fassungen - Portalámparas Disponibles:

 art. 172/E14  art. 104  art. 122	 art. 138  art. 139  art. 122	 art. 173  art. 101  art. 122	<p style="text-align: right;">Autoestinguenti Fireproof</p>  art. 172  art. 132
---	---	---	---

waterproof

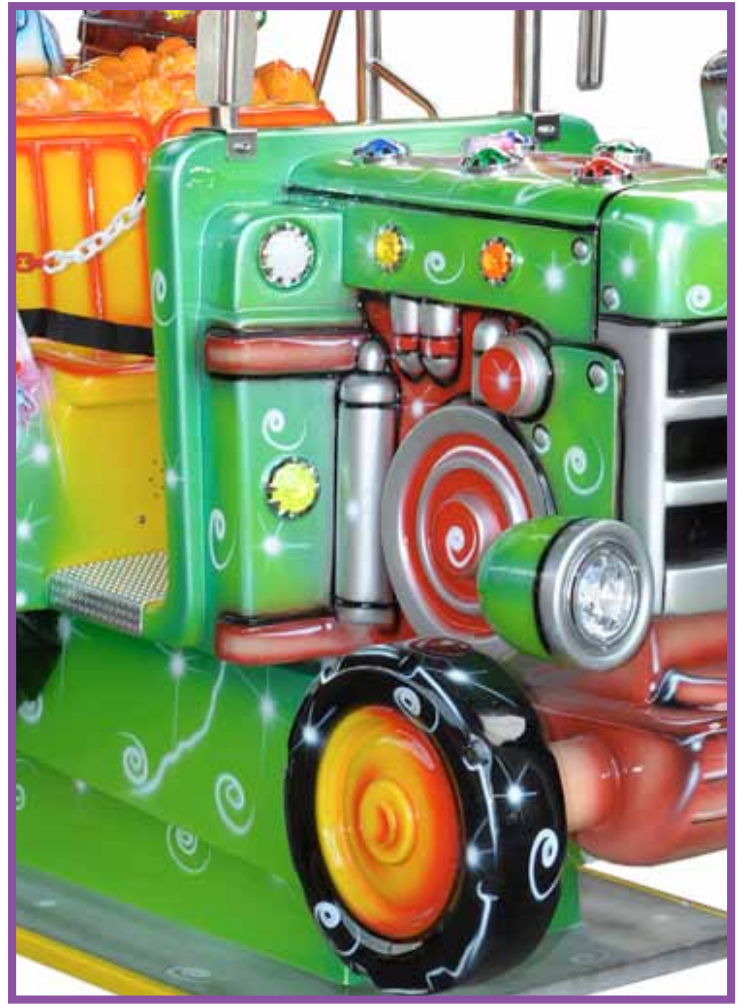
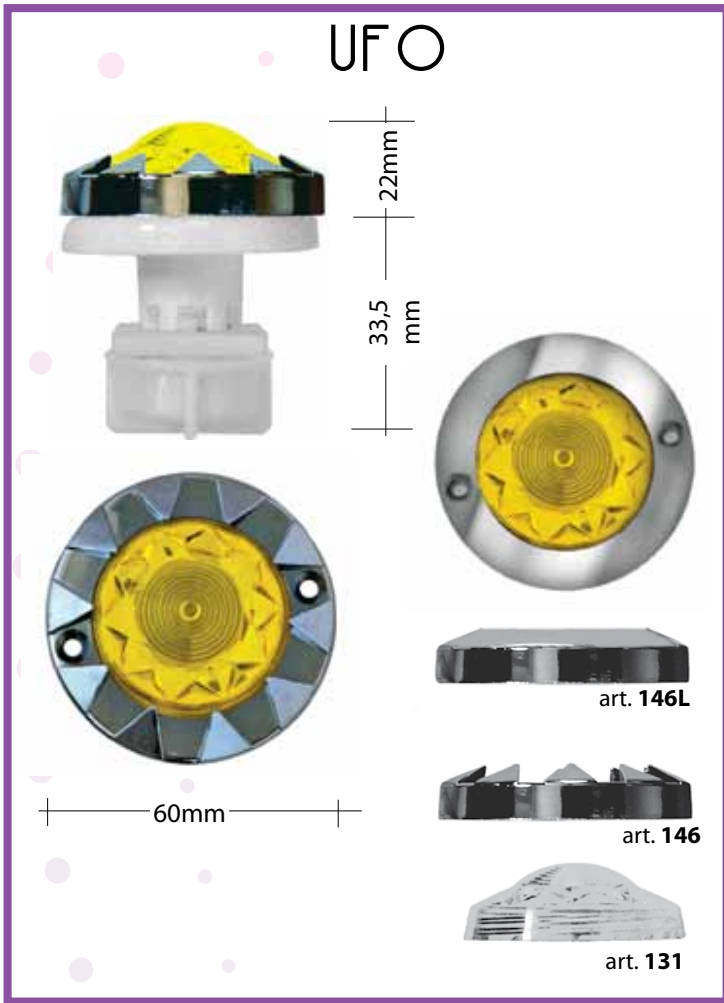

COLORI DISPONIBILI:



Lampade Disponibili - Ampoules Disponibles - Available Lamps - Verfügbar Lampen - Lámparas Disponibles:



8 LED
art. 268 = E10
24v - 0,6w



8 LED
art. 269 = E10
60v - 0,6w



E10
art. 212 60V - 4w TW/LP
art. 213 60V - 3w
art. 207 24V - 3w LP
art. 202 12V - 3w



8 LED
art. 271 = E10
24v - 0,6w
art. 272 = E10
60v - 0,6w

Portampada Disponibili - Douilles Disponibles
Available Sockets - Verfügbar Fassungen
Portalámparas Disponibles:



art. 137



Autoestinguenti
Fireproof

art. 171

art. 170



art. 101



art. 132

art. 122



Waterproof

SPOT E14

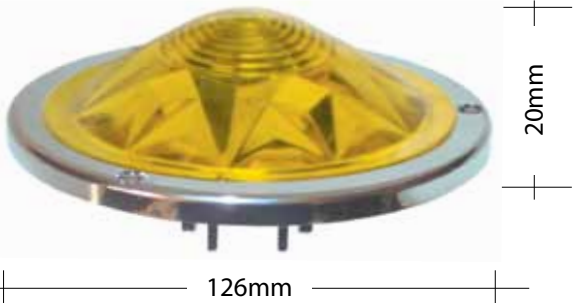

126mm

20mm



art. 510
art. 108
art. 520

FANALINO VETTURA



115mm

20mm

100mm



art. 191
art. 108
art. 192

COLORI DISPONIBILI:

- T1 Red
- T2 Yellow
- T3 Green
- T4 Orange
- T6 White
- T7 Clear
- T8 Blue

Lampade Disponibili - Ampoules Disponibles - Available Lamps - Verfügbar Lampen - Lámparas Disponibles:

					
art. 267 = E14 24v - 1,5w 6 LED RGB Multicolor	T1 LED art. 258 = E14 24v - 1w art. 259 = E14 60v - 1w	T1 LED art. 260 = E14 24v - 1w art. 261 = E14 60v - 1w	Strobo Led art. 283 24V	Strobo art. 872 60V A art. 873 110V art. 874 220V Pilot B art. 875 220V	art. 203 60V - 8w art. 205 60V - 10w art. 208 24V - 5w art. 209 14V - 5w L. art. 211 230V - 7w

Portampada Disponibili - Douilles Disponibles
Available Sockets - Verfügbar Fassungen
Portalámparas Disponibles:







art. 104
Autoextinguenti
Fireproof



art. 140



art. 122

-  Fanali con filtro in policarbonato colorato in vari colori. Disponibili con parabole e ghiera in ABS con cromature galvaniche ad alta resistenza o di colore nero. Possibilità di utilizzo di diversi portampada E14, lampada alogena e lampada led RGB. Ottimo per finiture luminose di gioiote di grandi dimensioni.
-  Projecteurs avec filtre en polycarbonate de diverses couleurs. Disponibles avec paraboles et embouts en ABS avec chromage galvanique à haute résistance ou de couleur noire. Possibilité d'utilisation de différentes douilles E14 et lampe halogène. Adapté aux finitions lumineuses des manèges de grandes dimensions.
-  Lamp with polycarbonate filter available in various colours. Available with parabolas and ring nuts in black or ABS with galvanic chromium plating high resistance. Possibility of using various E14 sockets and halogen lamps. Superb for lighting features for large amusement rides.
-  Schlusslichter mit Polykarbonatfilter in verschiedenen Farben. Erhältlich mit Parabeln und Ringen aus ABS widerstandsfähiger Vercromung oder in schwarzer Farbe. Kann in verschiedenen E14 ampfenfassungen und Halogenlampen verwendet werden. Optimal für die Leuchtränder von großen Karussellen.
-  Focos con filtro en policarbonato de distintos colores. Disponibles con parábolas y tuercas en ABS cromados galvanicos y alta resistencia o de color negro. Posibilidad de utilización de diferentes portalámparas E14 y lámpara halógena. Ideal para acabados luminosos de tiouvivos de gran tamaño.

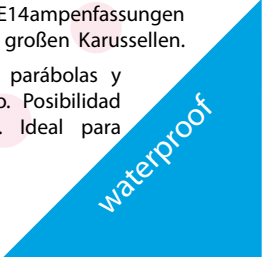

HALOSPOT

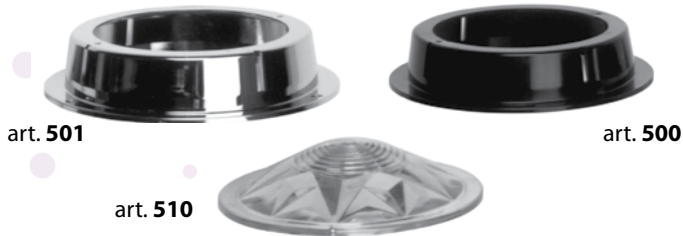
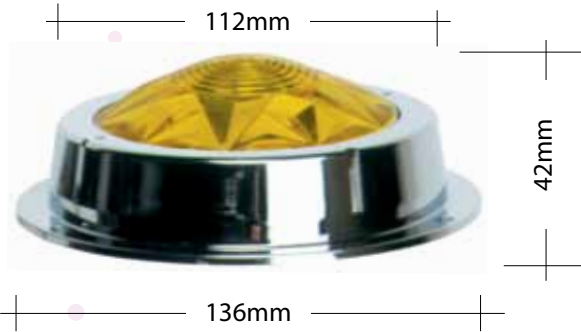

COLORI DISPONIBILI:



Lampade Disponibili - Ampoules Disponibles - Available Lamps - Verfügbar Lampen - Lámparas Disponibles:

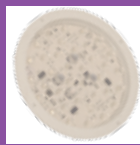

Art. 196 led PAR 36
24V - 5W
Ø 110mm



Art. 197 Rotoled
24V - 5W
Ø 110mm



Art. 356
ALOGENA 6/12 V
Lampada/Bulb
HALOSPOT 35W 6V



Fanali con filtro in policarbonato colorato in vari colori. Disponibili con parabole e ghiera in ABS con cromature galvaniche ad alta resistenza o di colore nero. Possibilità di utilizzo di diversi portalampada E14, lampada alogena e lampada led RGB. Ottimo per finiture luminose di giostrine di grandi dimensioni.



Projecteurs avec filtre en polycarbonate de diverses couleurs. Disponibles avec paraboles et embouts en ABS avec chromage galvanique à haute résistance ou de couleur noire. Possibilité d'utilisation de différentes douilles E14 et lampe halogène. Adapté aux finitions lumineuses des manèges de grandes dimensions.



Lamp with polycarbonate filter available in various colours. Available with parabolos and ring nuts in black or ABS with galvanic chromium plating high resistance. Possibility of using various E14 sockets and halogen lamps. Superb for lighting features for large amusement rides.



Schlusslichter mit Polykarbonatfilter in verschiedenen Farben. Erhältlich mit Parabeln und Ringen aus ABS widerstand Föhiger Vercrom Mung oder in schwarzer Farbe. Kann in verschiedenen E14 ampfassungen und Halogenlampen verwendet werden. Optimal für die Leuchtränder von großen Karussellen.



Focos con filtro en policarbonato de distintos colores. Disponibles con parábolas y tuercas en ABS cromados galvánicos y alta resistencia o de color negro. Posibilidad de utilización de diferentes portalámparas E14 y lámpara halógena. Ideal para acabados luminosos de tiouvivos de gran tamaño.

waterproof

FANALINO MOTO

80mm
50mm

art. 147 art. 144 art. 138 art. 195

Lampade
Ampoules
Lamps
Lampen
Lámparas

FENDINEBBIA

126mm
55mm

art. 510 art. 520 art. 521

Lampade
Ampoules
Lamps
Lampen
Lámparas

Portampada
Douilles
Sockets
Fassungen
Portalámparas

COLORI DISPONIBILI:



Lampade Disponibili - Ampoules Disponibles - Available Lamps - Verfügbar Lampen - Lámparas Disponibles:

					
art. 267 = E14 24v - 1,5w 6 LED RGB Multicolor	T1 LED art. 258 = E14 24v - 1w art. 259 = E14 60v - 1w	T1 LED art. 260 = E14 24v - 1w art. 261 = E14 60v - 1w	Strobo Led art. 283 24V	Strobo art. 872 60V A art. 873 110V art. 874 220V Pilot B art. 875 220V	art. 203 60V - 8w art. 205 60V - 10w art. 208 24V - 5w art. 209 14V - 5w L. art. 211 230V - 7w

Portampada Disponibili - Douilles Disponibles
Available Sockets - Verfügbar Fassungen
Portalámparas Disponibles:



art. 104



art. 140







art. 138 E10

Autoestinguenti
Fireproof



art. 122

-  Fanali con filtro in policarbonato colorato in vari colori. Disponibili con parabole e ghiera in ABS con cromature galvaniche ad alta resistenza o di colore nero. Possibilità di utilizzo di diversi portalampada E14, lampada alogena e lampada led RGB. Ottimo per finiture luminose di gioiote di grandi dimensioni.
-  Projecteurs avec filtre en polycarbonate de diverses couleurs. Disponibles avec paraboles et embouts en ABS avec chromage galvanique à haute résistance ou de couleur noire. Possibilité d'utilisation de différentes douilles E14 et lampe halogène. Adapté aux finitions lumineuses des manèges de grandes dimensions.
-  Lamp with polycarbonate filter available in various colours. Available with parabolas and ring nuts in black or ABS with galvanic chromium plating high resistance. Possibility of using various E14 sockets and halogen lamps. Superb for lighting features for large amusement rides.
-  Schlusslichter mit Polykarbonatfilter in verschiedenen Farben. Erhältlich mit Parabeln und Ringen aus ABS widerstand Föhiger Vercrom Mung oder in schwarzer Farbe. Kann in verschiedenen E14 ampfenfassungen und Halogenlampen verwendet werden. Optimal für die Leuchtränder von großen Karussellen.
-  Focos con filtro en policarbonato de distintos colores. Disponibles con parábolas y tuercas en ABS cromados galvánicos y alta resistencia o de color negro. Posibilidad de utilización de diferentes portalámparas E14 y lámpara halógena. Ideal para acabados luminosos de tiouvivos de gran tamaño.

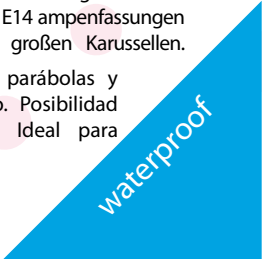



Come complemento delle attrazioni Imel Park offre una serie di proiettori luminosi e di effetti speciali che rendono particolare ed unica l'ambientazione del vostro spettacolo. oltre ai prodotti classici da discoteca la gamma si completa con nuove lampade a led RGB con alta luminosità e nuovi effetti.



En guise de complément des attractions, Imel Park offre une série de projecteurs lumineux et d'effets spéciaux qui rendent l'atmosphère de votre spectacle particulière et unique. En plus des produits classiques pour discothèque, la gamme se complète de nouvelles lampes à diodes RGB à forte luminosité et, de nouveaux effets.



The Imel Park range is completed by a series of light projectors and special effects, which can be used to create a unique setting for your show or event. In addition to traditional disco equipment, the range also features new RGB LED lamps with high luminosity and new effects.



Zur Vervollständigung der Attraktionen bietet Imel Park eine Reihe von Lichtprojektoren und Spezialeffekten, die die Bühnenausstattung für Ihre Aufführung zu etwas Besonderem und Einmaligem machen. Neben den klassischen Diskothekenobjekten wird die Produktlinie durch die neuen RGB-Led_Lampen mit hoher Leuchtkraft und neuartigen Effekten ergänzt.



Para completar las atracciones, Imel Park ofrece una serie de proyectores luminosos y efectos especiales que hacen que la ambientación de su actuación sea especial y única. Además de los productos clásicos para discoteca, la gama se completa con nuevas lámparas LED RGB de alta luminosidad y nuevos efectos.

MACCHINA DEL FUMO



Macchina per la produzione di fumo scenografico, completa di radiocomando.



Machine pour la production du fumée scénographique, avec radioguidage.



Machine for the production of fog, complete with remote control.



Gerät zur Produktion von Bühnenrauch, samt Fernbedienung.



Máquina para la producción de humo espectacular, con sistema de radiocontrol.

Alimentazione: 220-240V - 50 Hz

Consumo: 1200 W

Dimensioni: 50x20x30cm

Peso: 5Kg

- Contenitore liquido estraibile da 3Lt.
- Consumo liquido 60ml/min. (c.ca)
- Emissione fumo 500 mc/min (c.ca)
- Protezione termica diretta con interruzione dell'alimentazione in caso di surriscaldamento.

Power supply: 220-240V - 50Hz

Power consumption: 1200 W

Dimension: 50x20x30cm

Weight: 5Kg

- Fluid capacity 3Lt.
- Fluid consumption 60 ml/min (c.ca)
- Smoke output 500 mc/min (c.ca)
- Thermal cut-off safety switch.

waterproof

FIREBALL



Soggetto da discoteca, completo di lampada. 

Objet pour les discothèques complète avec ampoule. 

Disco Objects, with lamp. 

Für Diskotheken, samt Lampe. 

Tema para discoteca, con portalámpara. 

SPHERION LED



Soggetto da discoteca LED Bianchi o RGB. 

Objet pour les discothèques LED blancs ou RGB. 

Disco Objects white or RGB-LED. 

Lampe für Diskotheken Weiß-oder RGB-LED. 

Tema para discoteca Blanco o RGB LED. 

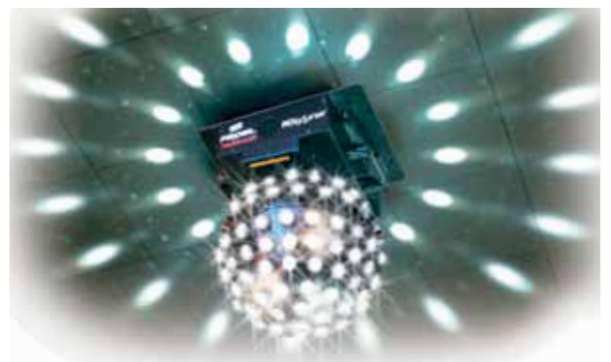

DMEMORY XP70



Proiettore Led ad alta efficienza luminosa e durata media 50.000 ore.

Projecteur à Led avec efficacité lumineuse et durée de vie moyenne 50.000 heures.

High efficiency Led floodlight with average life of 50.000 hours.

Projektor-LED mit hoher Lichtausbeute und Lebensdauer durchschnittlich 50.000 Stunden.

Proyector Led RGB con alta eficacia luminosa y vida media de 50.000 horas.



Alimentazione: 195-265V
Consumo: 70 W
Colore luce: 4000° K
Dimensioni: 26,5x9,5x31cm
Peso: 4,3Kg
CE IP65

Power supply: 195-265V
Power consumption: 70 W
Light colour: 4000° K
Dimension: 26,5x9,5x31 cm
Weight: 4,3Kg
CE IP65

STROBO STAGNO



Faro stagno con strobo 1 o 2 lampade 1500W o 3000W.

Lumière stroboscopique Waterproof avec une ou deux lampes 1500w

Waterproof strobo light with one or two lamps 1500w

Waterproof Strobo-Licht mit ein oder zwei Lampen 1500w

Luz estrobo Waterproof con un o dos lámparas 1500w



Alimentazione: 220V
Consumo: 1500/3000 W
Dimensioni 1500W: 47x52x17cm
Dimensioni 3000W: 51x49x29cm
Peso 1500W: 7Kg
Peso 3000W: 13Kg

Power supply: 220-240V
Power consumption: 70 W
Dimension 1500W: 47x52x17cm
Dimension 3000W: 51x49x29cm
Weight 1500W: 7Kg
Weight 3000W: 13Kg

FARO ALOGENO



Faro alogeno 500/1000/1500W con filtri colorati intercambiabili. Disponibile anche nel modello LEG MX 1500 W.

Phare halogène 500/1000/1500W avec verres colorés interchangeables. Disponibles aussi en LEG MX 1500 W.

Halogen spotlight 500/1000/1500W with interchangeable colored glass. Available also in LEG MX 1500 W.

Halogen-Spot 500/1000/1500W mit austauschbaren Filtern. Verfügbar auch in LEG MX 1500W.

Halógeno 500/1000/1500W con filtros colorados intercambiables. Disponibles también LEG MX 1500 W.



Alimentazione: 220V
Consumo: 500 / 1000 / 1500 W
Dimensioni 500W: 19x15,5x20cm
Dimensioni 1000W: 33x22,5x17cm
Dimensioni 1500W: 40x22,5x17cm
Peso 500W: 2,6Kg
Peso 1000W: 3,8Kg
Peso 1500W: 4,2Kg

Power supply: 220-240V
Power consumption: 500 / 1000 / 1500 W
Dimension 500W: 19x15,5x20cm
Dimension 1000W: 33x22,5x17cm
Dimension 1500W: 40x22,5x17cm
Weight 500W: 2,6Kg
Weight 1000W: 3,8Kg
Weight 1500W: 4,2Kg

CENTRALINE ELETTRONICHE



Realizzate in base alle dimensioni ed alla potenza richieste. Dalla progettazione alla realizzazione. Il servizio Imel park include la progettazione e realizzazione di centraline e quadri elettrici di comando e controllo delle luminarie di giostre e attrazioni. Sulla base delle specifiche tecniche fornite dal cliente i nostri prodotti sono assemblati nel laboratorio interno e sono accompagnati da progetto e conformità alle più aggiornate normative per la sicurezza.

Si realizzano anche assemblaggi e cablaggi di semilavorati che sarà cura del cliente includere nel progetto complessivo del suo prodotto.



Construit selon la taille et les besoins en puissance demandées. De la conception du projet à la réalisation. Le service Imel park inclut la conception et la réalisation de centrales et de tableaux électriques de commande et de contrôle des luminaires pour manèges et attractions. En fonction des spécifications techniques fournies par nos clients, nos produits sont assemblés dans le laboratoire interne et sont accompagnés d'un projet en conformité aux normes de sécurité les plus à jour. Nous récusons assemblages et câblages de produits semi-finis dont nos clients auront la responsabilité d'inclure dans le projet global du produit.



Made in accordance with the size and the power requirements. From design to manufacture. The Imel Park service includes the design and manufacture of control units and electric panel for controlling the lighting of rides and attractions. On the basis of technical specifications provided by the client, our products are assembled in the in-house workshop and are accompanied by a plan that conforms to the latest safety regulations. We also produce semifinished assemblies and wiring harnesses that can be used by the customer in his own projects.



Hergestellt gemäß gewünschte Größen und Vermögen. Von der Planung zur Verwirklichung. Im Serviceangebot von Imel Park ist die Planung und Verwirklichung von Steueranlagen und elektrischen Schalttafeln für die Steuerung und Kontrolle der Beleuchtung von Karussellen und Attraktionen eingeschlossen. Aufgrund der vom Kunden gelieferten technischen Spezifikationen werden unsere Produkte in der eigenen Werkstatt zusammengesetzt und von Plänen begleitet, die den aktuellsten rechtlichen Sicherheitsvorschriften entsprechen. Es wird auch die Zusammensetzung und Verkabelung von Halbfertigprodukten durchgeführt; der Kunde sorgt dafür, diese im Gesamtplan zu seinem Produkt einzuschließen.



Realizadas según las dimensiones y la potencia requeridas. Del diseño a la realización de centralitas y cuadros eléctricos de mando y control de los sistemas de iluminación de tirovivos y atracciones. En base a las especificaciones técnicas suministradas por el cliente, nuestros productos se ensamblan en el laboratorio interior y están acompañados por un proyecto en conformidad a las más actualizadas normativas de seguridad. También se realizan ensamblados y cableados de semielaborados, que el cliente se hará cargo de incluir en el proyecto global de su producto.

Scheda programmabile 8 canali
Fiche programmable 8 canaux
8 Channel programmable board
Programmierbare Jarte 8 Kanäle
Tarjeta programable 8 canales

Scheda di espansione 8 canali
Fiche d'expansion 8 canaux
8 Channel expansion board
Erweiterungskarte 8 Kanäle
Tarjeta de expansión 8 canales



Centralina 3x40A
3x40A Centrale
3x40A Control unit
3x40A Steueranlage
3x40A Centralita



SPINE E PRESE



Fornitura completa di spine e prese per installazioni, disponibili in tutte le versioni e modelli. Nell'ottica del servizio il nostro magazzino è fornito di una completa gamma di spine e prese per il collegamento di tutti i prodotti da noi forniti, in modo che il cliente possa avere tutto il necessario per le sue installazioni e manutenzioni attraverso un unico fornitore di riferimento.



Fourniture complète de fiches et prises pour installations, disponible dans tous les versions et modèles. Dans le cadre de ce service, notre magasin est pourvu d'une gamme complète de fiches et de prises pour la connexion de tous les produits que nous fournissons de manière à ce que nos clients puissent disposer du nécessaire pour leurs installations et l'entretien à travers un unique fournisseur de référence.



Complete supply of plugs and sockets for installations, available in all versions and models. In view of the service we provide, our warehouse is stocked with a complete range of plugs and sockets for connecting all the products we supply. In this way, the customer can be provided with everything he needs for installation and maintenance by a single supplier.



Komplette Lieferung von Steckern und Steckdosen für die Anlagen, in alle Versionen und Modellen erhältlich. In Hinsicht auf den Service ist unser Lager mit der kompletten Linie von Steckern und Steckdosen für die Installation und Instandhaltung notwendige durch ein und denselben Lieferanten beziehen kann.



Suministro completo de clavijas y tomas para instalaciones, disponibles en todas las versiones y modelos. Desde el punto de vista del servicio, nuestro almacén posee una completa gama de clavijas y tomas para conexión de todos los productos suministrados por nuestra empresa, para que el cliente pueda encontrar todo lo que necesite para sus instalaciones e intervenciones de mantenimiento a través de un único proveedor de referencia.



10 poli
10 pôles
10 poles
10 polig
10 polos



6 poli
6 pôles
6 poles
6 polig
6 polos



5 poli
5 pôles
5 poles
5 polig
5 polos



5 poli - versione a muro
5 pôles - version murale
5 poles - wall mounted version
5 polig - Wandversion
5 polos - versión de pared



art. **260 = E14**
24v - 1w

art. **261 = E14**
60v - 1w



art. **258 = E14**
24v - 1w

art. **259 = E14**
60v - 1w



art. **256-257=E14**
220/130v - 1,6w



art. **267 = E14**
24v - 1,5w
6 LED RGB
Multicolor

6 LED

Lampada Strobo • Lampes stroboscopiques • Strobe lamps • Stroboskopische lampe • Lámparas estroboscópicas



art. **283 = E14**
24v



E14

art. **872** 60V
art. **873** 110V
art. **874** 220V Pil.
art. **875** 220V

A Autolampeggiante sigillato nella resina • Clignotant - scellé dans la résine • Auto flash - sealed in the resin • Auto blinkt - in dem Harz versiegelt • Intermitente - sellado en la resina

B Pilotato sigillato nella resina • Piloté - scellé dans la résine • Piloted - sealed in the resin • Pilotiert - in dem Harz versiegelt • Piloteado - sellado en la resina

Lampade ad incandescenza • Lampe à incandescence • Incandescent lam • Glühlampe • Lámpara de incandescencia



art. **203** 60V - 8w
art. **205** 60V - 10w
art. **208** 24V - 5w
art. **209** 14V - 5w L.
art. **211** 230V - 7w

OSRAM LED

E14



art. **258/E10 = E10**
24v - 1w

art. **259/E10 = E10**
60v - 1w



art. **268 = E10**
24v - 0,6w



8 LED

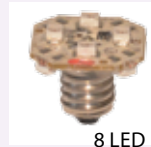

art. **269 = E10**
60v - 0,6w



8 LED



art. **267/E10 = E10**
24v - 1,5w
6 LED RGB Multicolor

6 LED



art. **271 = E10**
24v - 0,6w



8 LED

art. **272 = E10**
60v - 0,6w



Lampade ad incandescenza • Lampe à incandescence • Incandescent lam • Glühlampe • Lámpara de incandescencia



art. **212** 60V - 4w TW/LP
art. **213** 60V - 3w
art. **207** 24V - 3w LP
art. **202** 12V - 3w

OSRAM LED

E10

LAMPADE DICROICHE - LAMPES DICHROÏQUES - DICHROIC LAMPS
DICHROITISCHE LAMPE - LÁMPARAS DICROICAS



art. **186:**
Ø 35mm
12v/24v - 20w



art. **183:**
Ø 51mm
12v/24v - 20w



LAMPADE DICROLED • LAMPES DICROLED • DICROLED LAMPS •
DICROLED LAMPE • ÁMPARAS DICROLED



art. **281:**
Ø 35mm
12v/24v



art. **280:**
Ø 51mm
12v/24v



○ Bianca • Blanc • White • Weiß • Blanco

○ Trasparente • Transparent • Clear • Transparent • Transparente

○ Bianco caldo • Blanc chaud • Warm white • Warmweiß • Blanco cálido

● Giallo • Jaune • Yellow • Gelb • Amarillo

● Arancione • Orange • Orange • Orange Naraja

● Rosso • Rouge • Red • Rot • Rojo

● Blu • Bleu • Blue • Blau • Azul

● Verde • Vert • Green • Grün • Verde

MULTICOLOR RGB



art. 267/P



art. 267



art. 172/E14



art. 140

art. 122



art. 140

art. 122



art. 104

ROTORLED PAR 36



art. 501

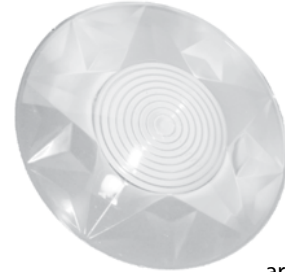

art. 510



art. 197

SPRING LED



art. 147



art. 282

DAISY LED

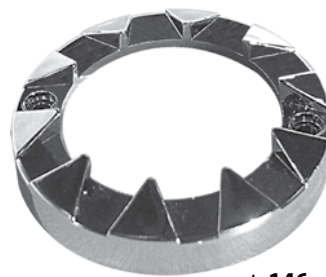

art. 146



art. 146L



art. 180

ROTORLED PAR HALOSPOT



art. 501

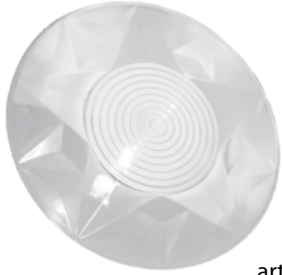

art. 510



art. 196

ROTORLED



art. 147



art. 134/L



art. 197/S

DICRO LED 51



art. 147



art. 181/C



art. 181



art. 182



art. 183



art. 280



art. 190



art. 190



art. 184



art. 184

DICRO LED 35



art. 146



art. 188



art. 189



art. 186



art. 281



art. 185



art. 185



art. 187



art. 187

CABOCHON E14



Lampade Disponibili - Ampoules Disponibles - Available Lamps
Verfügbar Lampen - Lámparas Disponibles

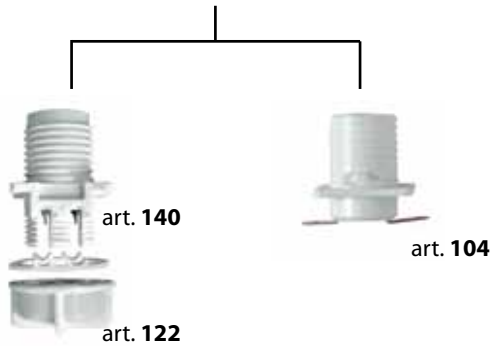

CABOCHON E10

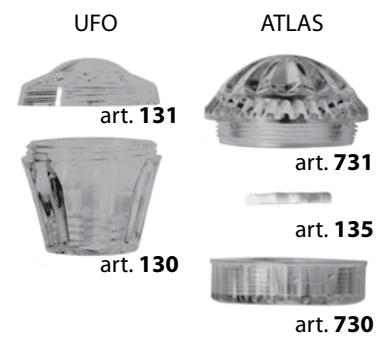

Lampade Disponibili - Ampoules Disponibles - Available Lamps
Lamps - Verfügbar Lampen - Lámparas Disponibles

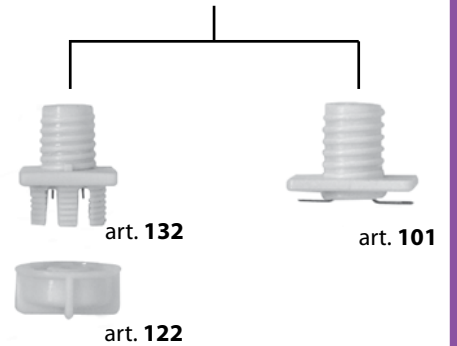

CABOCHON DA INCASSO



Lampade Disponibili - Ampoules Disponibles - Available Lamps
Verfügbar Lampen - Lámparas Disponibles

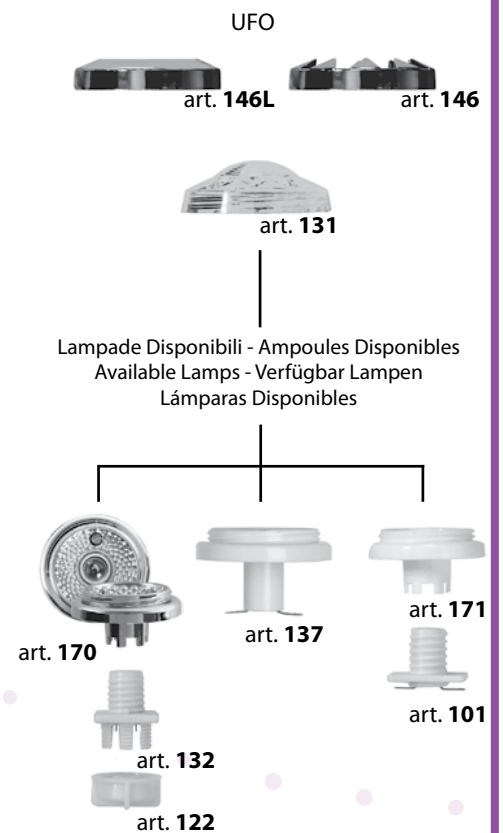
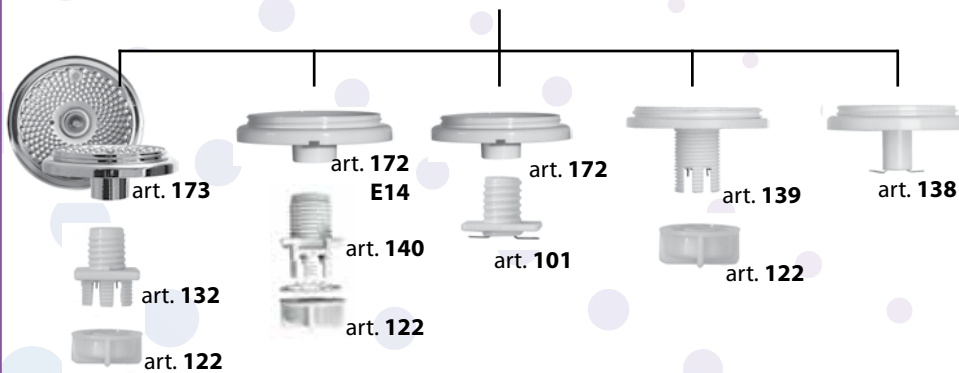

MODULO BIG

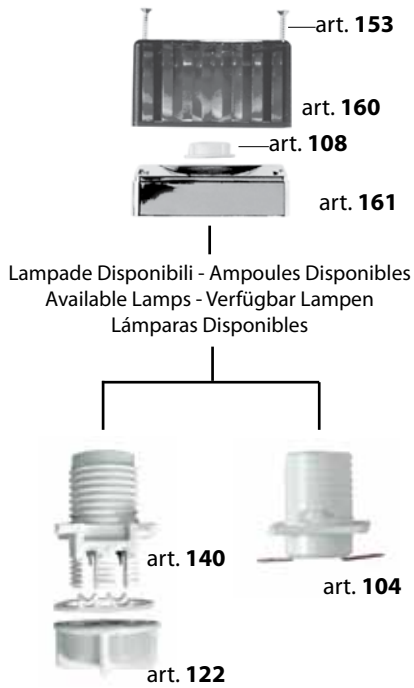

SPOT E14



NEONLUX



HALOSPOT

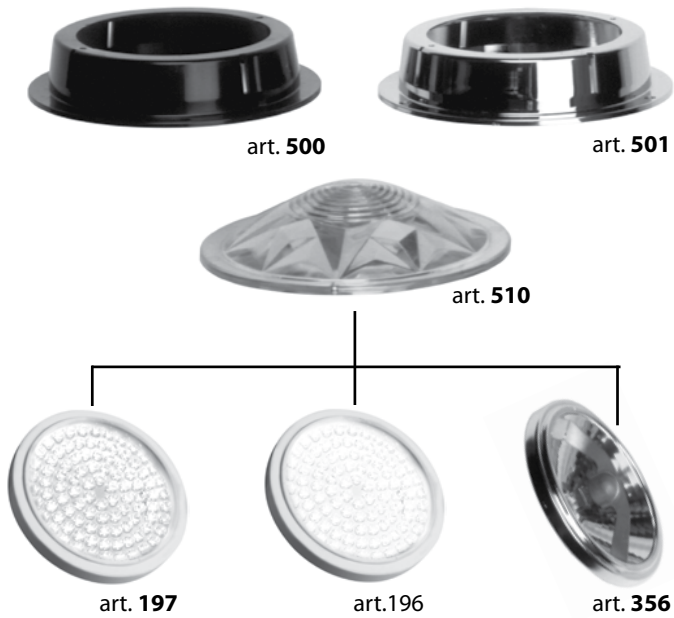

FANALINO VETTURA



FANALINO MOTO



FENDINEBBIA

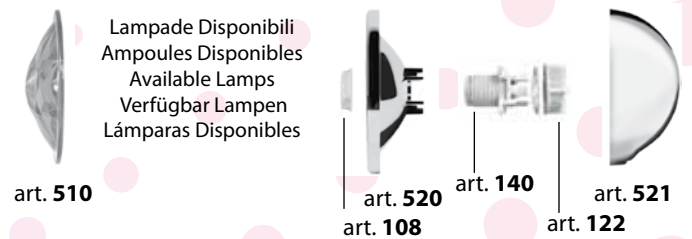

APPLICAZIONI

We Light up your Entertainments



Palma - Palmier
Palm - Palme - Palmera

Altezza/Height: 195cm
Larghezza/Width: 145cm
Peso/Weight: 22Kg



Palma da cocco
Cocotier - Coconut Palm
Kokospalme - Palma de
coco

Altezza/Height: 350cm
Larghezza/Width: 220cm
Peso/Weight: 87Kg

Sole - Soleil - Sun
Sonne - Sol

Altezza/Height: 200cm
Larghezza/Width: 200cm
Peso/Weight: 50Kg



Tour Eiffel
Altezza/Height: 350cm
Peso/Weight: 65Kg





Girasole - Tournesol
Sunflower - Sonneblume
Girasol
Altezza/Height: 180cm

Margherita con gambo
Marguerite avec tige
Daisy with stem
Margherite mit Stiel
Margarita con tallo
Ø150 cm



Cactus
Altezza/Height: 240cm
Peso/Weight: 22Kg

Brucofiore con gambo
Brucofiore avec tige
Brucofiore with stem
Brucofiore mit Stiel
Brucofiore con tallo
Altezza/Height: 180cm



Brucofiore
Altezza/Height: 80cm
Larghezza/Width: 80cm
Peso/Weight: 5Kg



Bandiera - Drapeau
Flag - Flagge - Bandera
Altezza/Height: 70cm
Larghezza/Width: 100cm
Peso/Weight: 20Kg



Colonna inox con Spot
Colonne inox avec Spot
Sainless steel column with Spot
Säule aus nichtrostendem Stahl mit Spot
Columna acero inoxidable con Spot



Colonna inox con Bijoux
Colonne inox avec Bijoux
Sainless steel column with Bijoux
Säule aus nichtrostendem Stahl mit Bijoux
Columna acero inoxidable con Bijoux

LAS VEGAS

KIN

KOSAK

1950

4D





JOYS

TEAP





IMEL PARK S.R.L.

VIA DEL CHIONSO 14/F - 42122 - REGGIO EMILIA ITALY - C.F./P.I. 00239010358
CAP. SOC. 103.200€ I.V. - SOC. SOTTOPOSTA A DIREZIONE E CONTROLLO BEAR PLAST SRL
PH. +39 0522 511501 - R.A. FAX +39 0522 514257 - INFO@IMELPARK.COM
WWW.IMELPARK.COM

